

# VOLVO PENTA AQUAMATIC DUOPROP

# D3-130, 160, 190/DP

96–120–140 kW (130–163–190 hp) crankshaft power acc. to ISO 8665

## Power for fun

Volvo Penta's 5-cylinder D3 is developed from the latest design in modern diesel technology. The engine is extremely lightweight and compact. With features like common rail fuel injection system, double overhead camshafts, 4 valves per cylinder, variable geometry turbocharger, aftercooler and the EVC (Electronic Vessel Control) a world-class diesel performance, combined with low emissions, is achieved.

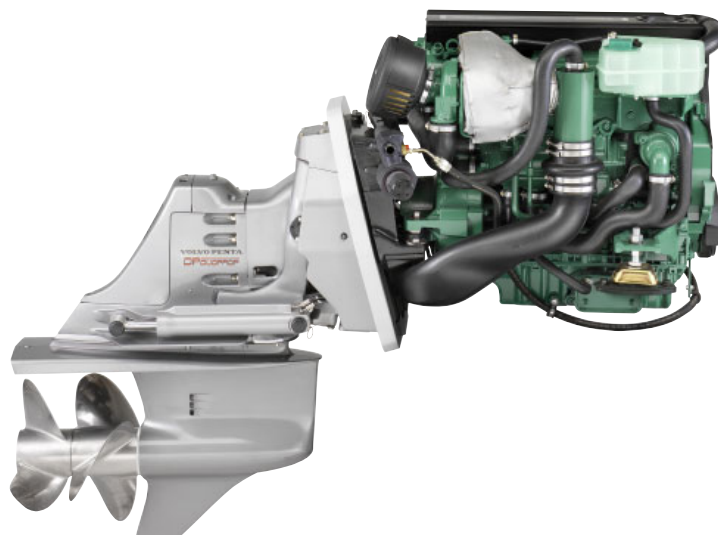

### World-class performance

The common rail fuel injection system, controlled by EVC, in combination with the large swept volume and Variable Geometry Turbine (VGT), ensures outstanding torque during acceleration, with virtually no sign of smoke. This matched with the engine's low weight creates a real performer for boating fun.

### Low weight

The engine has an extremely low weight for its power output. This thanks to the all aluminum base engine, and a highly efficient marinization. This contributes to a power/weight ratio comparable with a gasoline engine.

The engine is fitted with freshwater cooling as standard for long service life.

### Compact and robust

The engine is ultra-compact for its large swept volume. With cast-in grey iron cylinder liners, integrated freshwater pump, a compact marinization, and a fully symmetric engine, the package simply gets that compact.

The rigid aluminum cylinder block and bed plate in wedge structure, and exactly controlled high-pressure fuel injection gives excellent onboard comfort with low noise and vibration levels.

### EVC/MC - Plug and go

EVC Electronic Vessel Control is the latest development in instrumentation for marine engines with mechanical shift and throttle.

With EVC/MC you can tailor the instrumentation to fit the boat, from a single tachometer with an LCD window, where

you can read all engine/boat data, to a dashboard full with standard gauges or any combination in between. EVC/MC offers an optional multi-sensor to read speed, depth and surface water temp. The system is built on the latest automotive technology with waterproof connectors, so it's just plug and go.

EVC makes boating easier offering adjustable trim limits. EVC works closely together with the engine management system offering you constant power output regardless of temperature (5–55°C/41–131°F) and quality of the fuel.

### DP drive

The Duoprop drive with its twin counter-rotating propellers features exhaust outlets through the propeller hub and cavitation plate producing a harmonious drive unit with unbeatable characteristics in the boat in terms of speed, acceleration, steering, maneuvering, fuel economy and less noise and vibration.

The drive is equipped with a cone clutch for easy and smooth shifting, and easily maneuvered hydraulic power trim for obtaining the best running position at different sea and load conditions.

The D3/DP features standard Power steering for maximum driving comfort.

### Meeting new emission standards

The common rail injection system in combination with electronics and an advanced combustion system are setting new standards in minimizing noxious emissions and particles. The engine complies with the comprehensive emission requirements being introduced in Europe in 2006 and in the US in 2007.

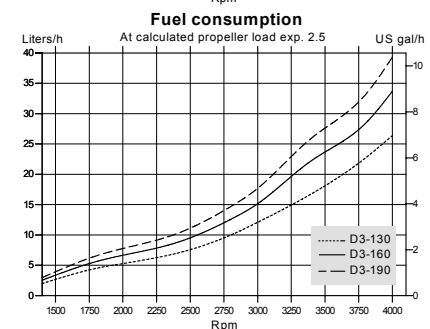
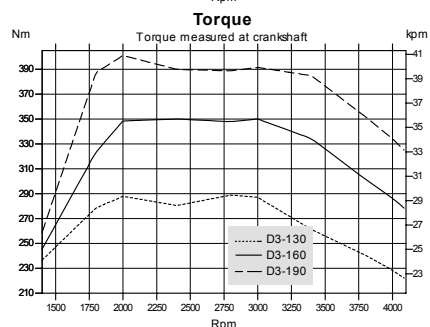
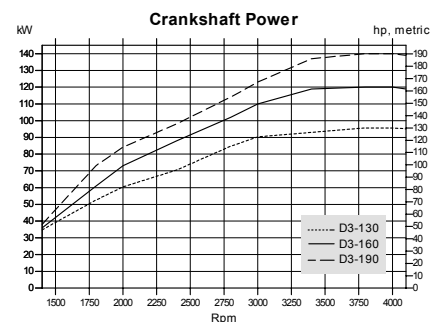

**VOLVO PENTA**

# D3-130, 160, 190/DP

## Technical description:

### Engine block and head

- Cylinder block and cylinder head made of aluminum
- Cylinder block with integrated bed plate
- 4-valve technology with hydraulic lash adjusters
- Double overhead camshafts
- Oil-cooled pistons with two compression rings and one oil scraper ring
- Cast-in grey iron cylinder liners
- Replaceable valve seats
- Six-bearing crankshaft
- Front-end transmission

### Engine mounting

- Flexible engine mounting

### Lubrication system

- Easily replaceable (insert) full-flow oil filter
- Plate oil cooler

### Fuel system

- Common rail fuel injection system
- Control unit for processing the injection
- Fine filter with water separator

### Air inlet and exhaust system

- Air filter with replaceable insert
- Closed crankcase ventilation with oil separator of cyclone type

- Stainless steel exhaust elbow
- Turbocharger with variable geometry

### Cooling system

- Thermostatically regulated freshwater cooling
- Tubular heat exchanger with separate large volume expansion tank
- Coolant system prepared for hot water outlet
- Easily accessible impeller pump
- Integrated seawater coolant pick-up through drive
- Seawater strainer

### Electrical system

- 12V one-pole electrical system
- 140A alternator, and integrated temperature compensated charging regulator
- Auxiliary stop button

### Instruments/control (options)

- Mechanical shift and throttle
- Full range of instrumentation including key switch and interlocked alarm available
- Digital Power Trim instrument with analog or digital reading
- Plug-in connectors

### Drive

- A variety of Duoprop propellers are available

- Cone clutch
- Pattern-matched spiral bevel gears
- Complete connection for exhaust outlet through the drive and hub
- Overload protection sleeve (break-away coupling)
- Max tilt angle 55°
- The drive can be turned 28° in each direction
- Built-in kick-up function to reduce possible damage, in the event the drive strikes an underwater object
- Active corrosion protection as accessory

### Power Trim

- Electrically operated hydraulic system for trimming the drive for best driving comfort
- An analog instrument for indication of trim angle

### Accessories

An extensive range of accessories are available. For detailed information, please see the Accessories & Maintenance Parts catalog ([www.volvopenta.com](http://www.volvopenta.com)).

Contact your local Volvo Penta dealer for further information.

Not all models, standard equipment and accessories are available in all countries. All specifications are subject to change without notice.

The engine illustrated may not be entirely identical to production standard engines.

## Technical Data

	<b>D3-130 A</b>	<b>D3-160 A</b>	<b>NEW! D3-190 A</b>
Engine designation			
Crankshaft power, kW (hp)	96 (130)	120 (163)	140 (190)
Propeller shaft power, kW (hp)	90 (122)	114 (155)	133 (181)
Engine speed, rpm	4000	4000	4000
Displacement, l (in <sup>3</sup> )	2.4 (146)	2.4 (146)	2.4 (146)
Number of cylinders	5	5	5
Bore/stroke, mm (in.)	81/93.2 (3.19/3.67)	81/93.2 (3.19/3.67)	81/93.2 (3.19/3.67)
Compression ratio	17.3:1	17.3:1	17.3:1
Volvo Penta Duoprop drive	<b>DP-S</b>	<b>DP-S</b>	<b>DP-S</b>
Ratio	2.11:1	2.11:1	1.95:1
Dry weight with DP, excl. prop., kg (lb)	330 (727)	330 (727)	330 (727)

Duty rating: R5

Technical data according to ISO 8665. With fuel having an LHV of 42,700 kJ/kg and density of 840 g/liter at 15°C (60°F). Merchant fuel may differ from this specification which will influence engine power output and fuel consumption.

The engine complies with the comprehensive emission requirements being introduced in Europe in 2006 and in the US in 2007.

## Dimensions D3-130, 160, 190/DP

Not for installation

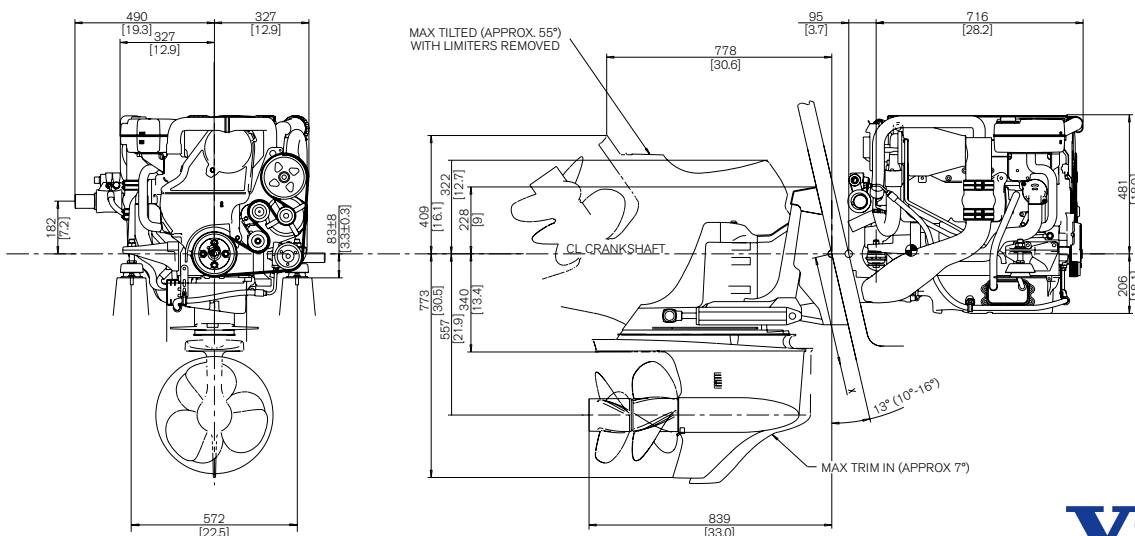

# VOLVO PENTA

**AB Volvo Penta**  
SE-405 08 Göteborg, Sweden  
[www.volvopenta.com](http://www.volvopenta.com)